

Technical data sheet

Product features



Electric range

Model

SAP Code

00008943



- Device type: Electric unit
- Device heating type: Indirect
- Steam pressure regulation: Mechanical - the valve releases steam at high pressure
- Filling: Mechanical cock
- Jacket filling: Semi-automatic
- Basin volume [l]: 50
- Usable volume [l]: 50

SAP Code	00008943	Loading	400 V / 3N - 50 Hz
Net Width [mm]	800	Basin volume [l]	50
Net Depth [mm]	730	Usable volume [l]	50
Net Height [mm]	900	Device heating type	Indirect
Net Weight [kg]	72.00	Steam pressure regulation	Mechanical - the valve releases steam at high pressure
Power electric [kW]	12.000		

Technical data sheet

Technical drawing



Electric range

Model

SAP Code

00008943

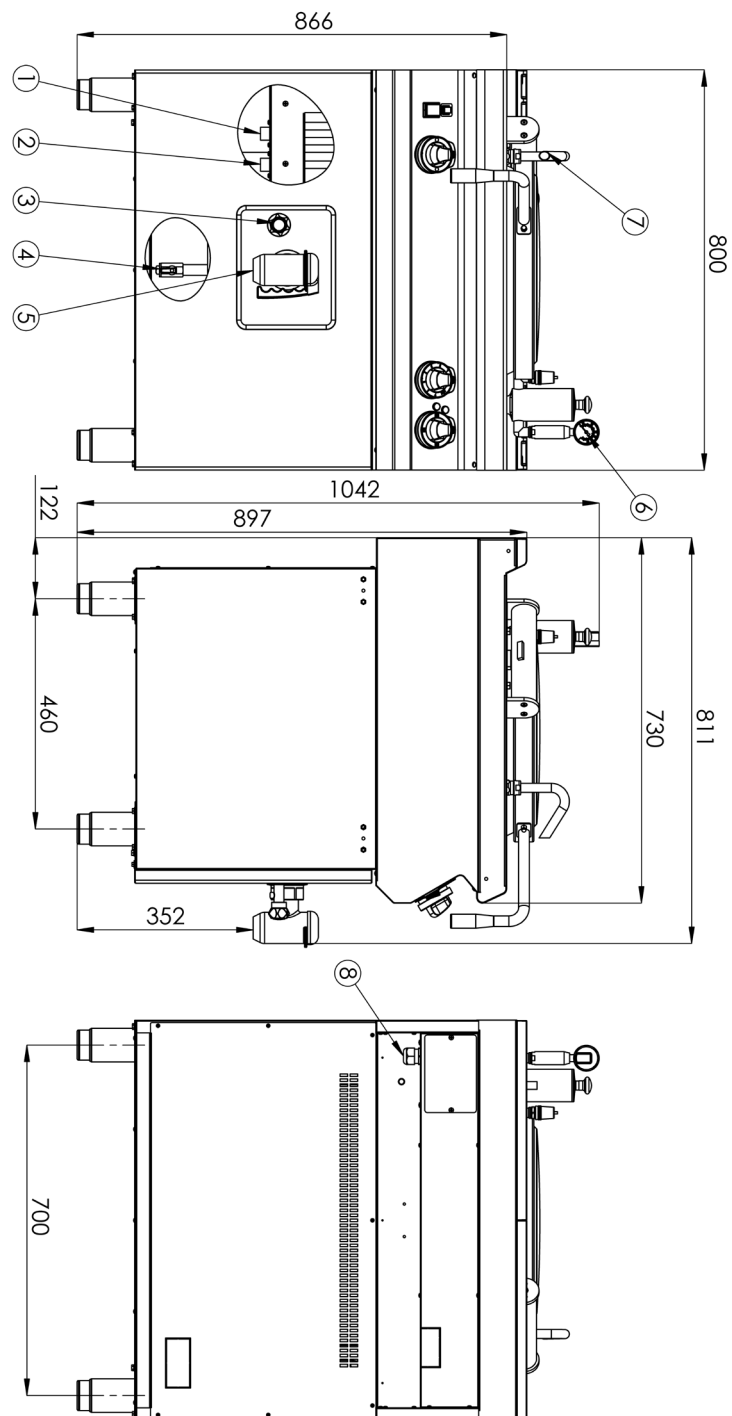

1 - PŘÍVOD STUDENÉ VODY	5 - VYPOUŠTĚČÍ KOHOUIT KOTLE
2 - PŘÍVOD TEPLÉ VODY	6 - POJISTNÝ VENTIL + MANOMETR
3 - KONTROLNÍ KOHOUIT HLADINY DUPUKÁTORU	7 - NAPOUŠTĚČÍ RAMINKO
4 - VYPOUŠTĚČÍ KOHOUIT DUPUKÁTORU	8 - PŘÍVOD EL. ENERGIE 400V/3N

Technical data sheet

Technical parameters



Electric range

Model

SAP Code

00008943

1. SAP Code:

00008943

2. Net Width [mm]:

800

3. Net Depth [mm]:

730

4. Net Height [mm]:

900

5. Net Weight [kg]:

72.00

6. Gross Width [mm]:

840

7. Gross depth [mm]:

800

8. Gross Height [mm]:

1065

9. Gross Weight [kg]:

83.00

10. Device type:

Electric unit

11. Construction type of device:

Stationary

12. Power electric [kW]:

12.000

13. Loading:

400 V / 3N - 50 Hz

14. Protection of controls:

IP24

15. Exterior color of the device:

Stainless steel

16. Material:

AISI 304 top plate and cladding

17. Indicators:

operation and warm-up

18. Worktop type:

Molded - comfortable cleaning maintenance

19. Worktop material:

AISI 304

20. Worktop Thickness [mm]:

1.50

21. Device heating type:

Indirect

22. Basin volume [l]:

50

23. Volume capacity of the container [l]:

50.00

24. Safety thermostat:

Yes

25. Adjustable feet:

Yes

26. Bottom material:

AISI 316

27. Type of pan:

Fixed

28. Usable volume [l]:

50

Technical data sheet

Technical parameters



Electric range

Model

SAP Code

00008943

29. Filling:

Mechanical cock

30. Jacket filling:

Semi-automatic

31. Steam pressure regulation:

Mechanical - the valve releases steam at high pressure

32. Type of drain valve:

conical

33. Manometer:

Yes

34. Water filling type:

Cold

35. Cross-section of conductors CU [mm²]:

4

– Výkon (kW): 30-37 (230 V); 53-64 (400 V)

36. Water supply connection:

1/2"